

PROFINET INTERFACE MODULE



NOTE

Keep the operating manual for future use!

ATTENTION

Subject to technical modifications!

About this instructions

Special notes in these instructions are marked with text and danger symbols.

NOTE

Notes or instructions that facilitate work and ensure a safe operation.

ATTENTION

The non-observance of these safety instructions can result in malfunctions or material damages.

WARNING

The non-observance of these safety instructions can lead to material damages and personal injuries.

Quality notes

The **sera** quality management and quality assurance system is certified in accordance with DIN EN ISO 9001:2015. The **sera** product complies with the applicable safety requirements and accident prevention regulations.

SAFETY INSTRUCTIONS	4
Personnel qualification and training	4
Dangers in the case of non-observance of the safety instructions	4
Safety-conscious working	4
Safety instructions for owner / operator	4
Improper operations	4
Intended use	4
TRANSPORT / STORAGE	5
General	5
Storage	5
PRODUCT DESCRIPTION	6
Type plate	6
Accessoires	6
TECHNICAL DATA	7
Electrical data	7
Ambient conditions	7
Dimensions	7
ELECTRICAL CONNECTIONS	8
Installation example / bus diagram	10
COMMISSIONING	11
LED operation indicators	12
OPERATION	12
Operation window	13
Operating Modes	13
Modules	13
Explanation of the modules	13
PROFINET acyclic data exchange	13
Modules / Input	14
Modules / Output	15
Settings (parameters)	15
Data from module to the master	22
MESSAGE	28
Diagnostics signals	28
Error message	28
MAINTENANCE / DECOMMISSIONING / DISPOSAL	29
Maintenance and cleaning	29
Decommissioning	29
Disposal	29



WARNING

Before commissioning, installing and during operation of the **sera** dosing pump the respective regulations valid at the place of installation are to be observed!

Compliance with these operating instructions and, in particular, the safety instructions, helps to:

- Prevent danger to people, machines and the environment.
- Increase reliability and service life of the product and the complete system.
- Reduce repair costs and downtimes.

Personnel qualification and training

The personnel for operation, maintenance, inspection and installation must be suitably qualified for their tasks. The owner must clearly define responsibility and supervision of the personnel.

If the personnel do not have the knowledge required, then personnel is to be trained and instructed correspondingly. Such training can be provided by the manufacturer / supplier upon order of the owner. In addition, the owner has to ensure that personnel have understood the operating instructions completely.

Dangers in the case of non-observance of the safety instructions

Non-observance of the safety instructions can result in hazards both for persons as well as for the environment and the product, and can, for example, cause the following hazards:

- Failure of important functions of the product.
- Failure of prescribed methods for maintenance and repair.
- Danger to people from electrical, mechanical and chemical influences.

Safety-conscious working

The safety instructions shown in this operating manual, the existing national accident prevention regulations and any internal working, operating and safety regulations of the owner must be observed.

Safety instructions for owner / operator

Danger caused by electrical energy is to be avoided.

Improper operations

Operating safety of the supplied product is only guaranteed if the product is used as intended, according to the descriptions in Chapter „Intended use“ of these operating instructions.

Intended use

The **sera** product is only to be deployed according to the intended purpose stated in the product description and the acceptance test certificate.

If the product is to be used for other applications, then the suitability of the product for the new operating conditions must be discussed with **sera** beforehand!

Criteria for operation in accordance with the intended use:

- Operating conditions at the place of installation.
- Voltage supply.

General

sera products are checked for perfect condition and function previous to shipment. Check for transport damage immediately after arrival of goods. If damage is found, this is to be reported immediately to the responsible carrier and the manufacturer.

Storage

An undamaged packaging protects the unit during storage and should only be opened when the product is installed. Proper storage increases the service life of the product and includes prevention of negative influences such as heat, moisture, dust, chemicals etc.

The following storage specifications are to be observed:

- Storage place: cool, dry, dustfree and slightly ventilated
- Storage temperature and relative air humidity see Chapter „TECHNICAL DATA“.
- The maximum storage time for the standard packaging is 12 months.

If these values are exceeded, metal products should be sealed in foil and protected from condensation water with a suitable desiccant.

Do not store solvents, fuels, lubricants, chemicals, acids, disinfectants and similar in the storage room.

PRODUCT DESCRIPTION

The INTERFACE MODULE must only be used as communication interface between a controllable sera dosing pump and a PROFINET network.

A proprietary **sera** protocol is used for the internal communication between INTERFACE MODULE and dosing pump.

i NOTE

The sera dosing pump PROFINET option is integrated in the network via the device master data (DMD) file which must be integrated in the development environment. This file contains the characteristics of the pump and information for the communication capability.

The DMD file can be downloaded by scanning the QR code (see type plate) or directly from the sera website www.sera-web.com.

Type plate

The INTERFACE MODULE is provided with a type plate at the factory. The information on the type plate is explained below.

No.	Designation
1	Type
2	Max. power consumption
3	Supply voltage
4	Protection rating
5	QR code (for the DMD file)



Accessoires

The following accessoires must be ordered separately:

- Wall mount (1)
- Sensor cable (2)

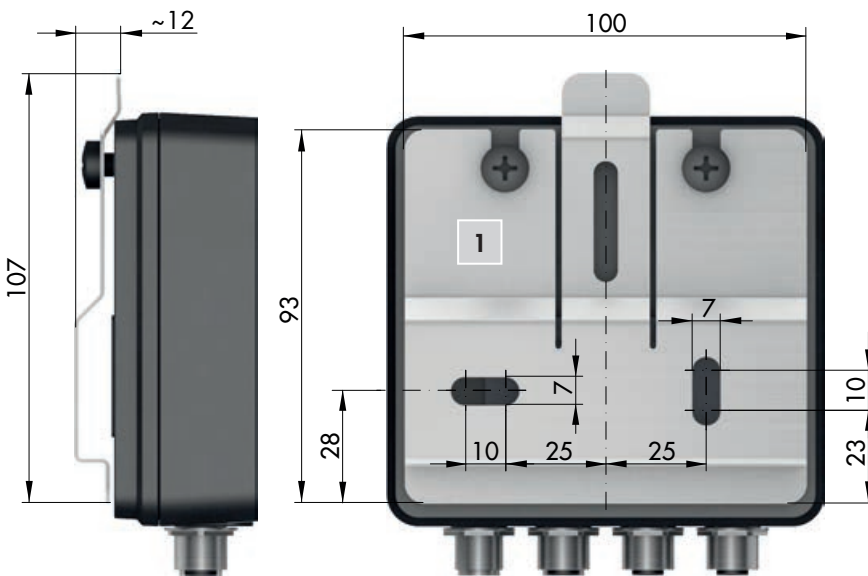

Electrical data

PROFINET interface	PROFINET IO RT 2 Port	
	Conformance Class	B
	PNIO Version	2.32
	GSD File sera	GSDML-V2.32- sera GmbH-Interface Modul-20160916.xml
Supply voltage	24V DC	
Max. power consumption	2 W	

Ambient conditions

Max. height above sea level (NN)	1000 m
Max. relative humidity	90%
Protection rating	IP65
Electrical protection class	III
Ambient temperature	0°C bis 40°C

Dimensions

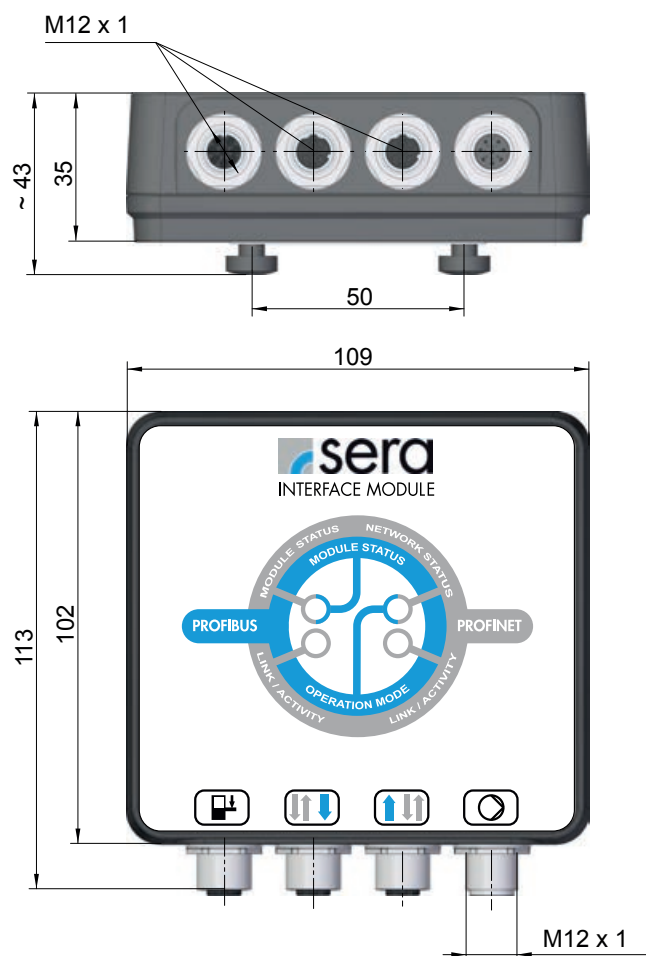

ELECTRICAL CONNECTIONS

⚠ ATTENTION

The electrical connection must be made by qualified personnel in compliance with the local regulations.

⚠ WARNING

Ensure absence of voltage of all cables and devices for the installation of electrical components!

Contact with stripped wires or live components can result in serious injuries or even death.
Any short-circuit can cause severe and expensive damage to the assemblies.

⚠ WARNING





Damaged cables should always be replaced!

⚠ WARNING

In order to guarantee the IP65 protection rating, all unused connections should be provided with a blanking plug.

⚠ ATTENTION

The PROFINET Installation Guideline must be taken into account for the installation and integration of the sera interface module.

	Interface	Assignment	Function
1	 Level connection	8-pole	Pre-alarm and dry running protection
2	 Port 1	4-pole	PROFINET connector 1
3	 Port 2	4-pole	PROFINET connector 2
4	 Pump connection	8-pole	Data transfer between pump and interface module

* no Y-connector necessary



Level connection (1)

Pin	Wire colour	Function (factory setting)
Pin 1	WH (white)	not assigned
Pin 2	BN (brown)	not assigned
Pin 3	GN (green)	not assigned
Pin 4	YE (yellow)	not assigned
Pin 5	GY (grey)	not assigned
Pin 6	PK (pink)	Pre-alarm level
Pin 7	BU (blue)	Dry run
Pin 8	RD (red)	GND

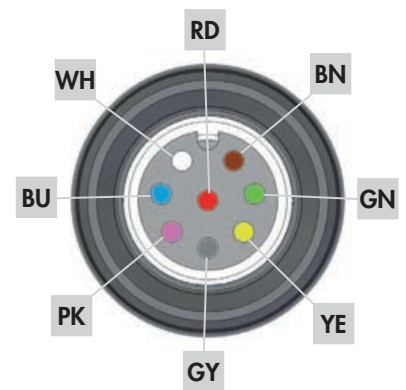

The inputs can be switched using a floating contact signal.
 Pre-alarm and dry running are set to normally open floating contacts at the factory.
 The sockets of the connections are A-coded and the assignments of the functions are symbolically labelled.

Port 1 (2) / Port2 (3)

Pin-Nr.	Aderfarbe	Signal	Beschreibung
Pin 1	YE (yellow)	TD+	Transmission Data +
Pin 2	OR (orange)	TD-	Transmission Data -
Pin 3	WH (white)	RD+	Receive Data +
Pin 4	BU (blue)	RD-	Receive Data -
Thread		Cable shield	Must be connected externally with PE via cable filter according to PROFINET standard

Pump connection (4)

Pin No.	Function
Pin 1	+24 V supply voltage
Pin 2	Communication IM1
Pin 3	Communication IM2
Pin 4	not assigned
Pin 5	Communication IM3
Pin 6	Pre-alarm level
Pin 7	Dry run -
Pin 8	GND

Installation example / bus diagram

Maximum segment length between two nodes with copper cable is 100 m.
The installation instructions for PROFINET must be observed for the cabling.

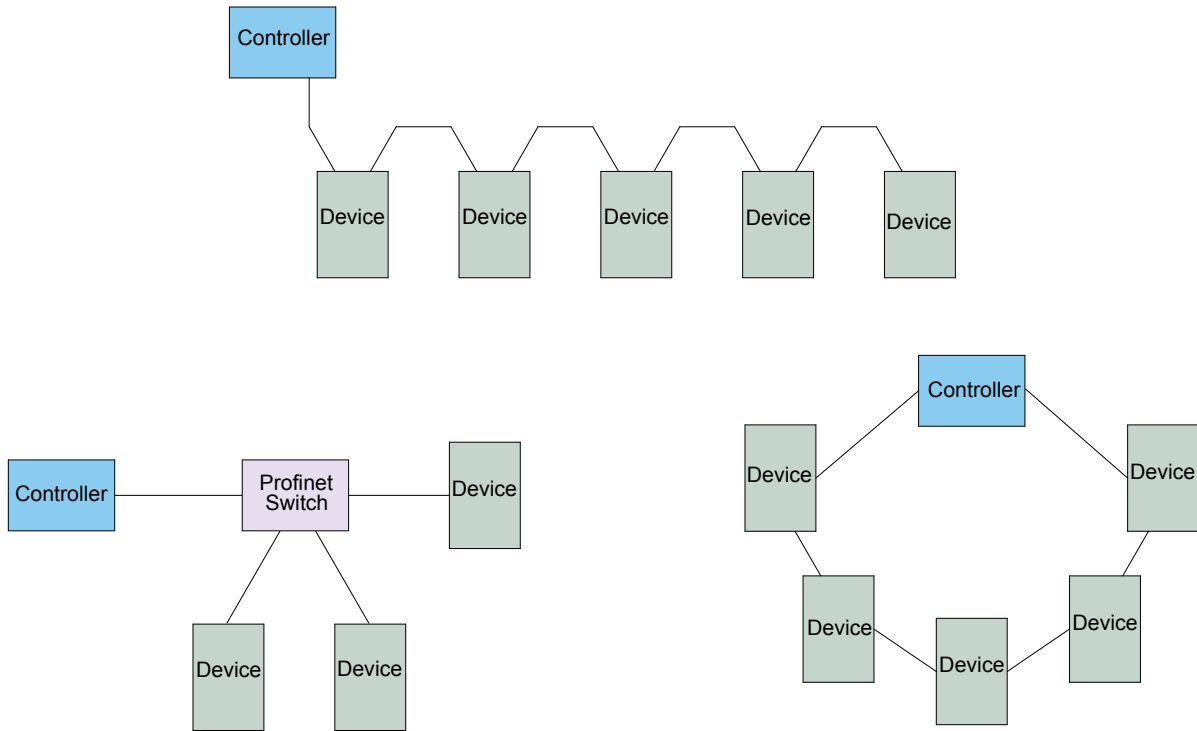

- Disconnect voltage.
- Connect INTERFACE MODULE (1) to the **sera** pump (2) (see „Electrical Connections). Observe earthing.



- Apply voltage.
- Pump starts.
- Module status (3) lights green.
- The "INTERFACE" operating mode must be enabled and can be selected for operating modes.

	INTERFACE
	Manual
	100.0 % freq.
	$\Sigma 0 N$

LED operation indicators

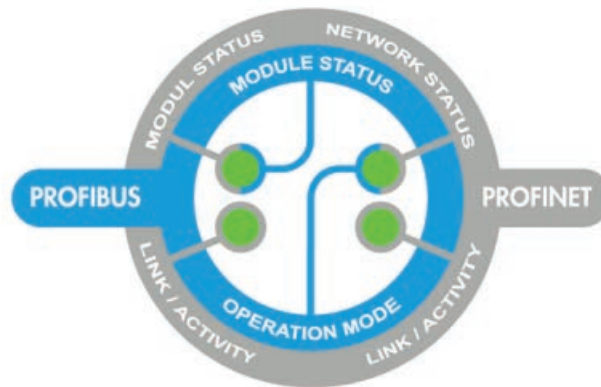

MODULE STATUS	<input type="radio"/> off	<input checked="" type="radio"/> green	<input checked="" type="radio"/> red
operational readiness		x	
diagnostics notification is pending		flashes	
module error			x
software update		flashes	flashes
not initialised	x		

NETWORK STATUS	<input type="radio"/> off	<input checked="" type="radio"/> green	<input checked="" type="radio"/> red
online, data exchange		x	
online (IO controller stop)		flashes once for a short time	
detection via Engineering tool		flashes	
module error			x
no connection to the IO controller	x		
station name not allocated			flashes once for a short time
IP address error			flashes twice for a short time
configuration error			flashes three times for a short time

LINK / ACTIVITY (1) (2)	<input type="radio"/> off	<input checked="" type="radio"/> green	<input checked="" type="radio"/> red
active		flashes	
connection / no communication		x	
no connection	x		

Operation window

INTERFACE MODULE is initialised.

No BUS/NETWORK connection is established or there is no data exchange.



BUS/NETWORK connection established.

Data exchange is present.

No operating mode has been selected in the PUMP_CONTROL module.



No valid process data exist.

Communication available.

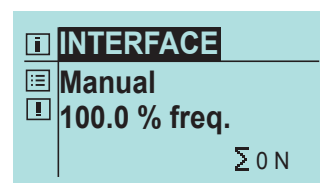

Operating Modes

The following operating modes are possible in interface operation:

- Manual
- Impulse
- Analog
- Batch

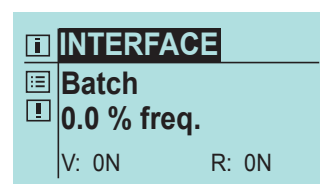
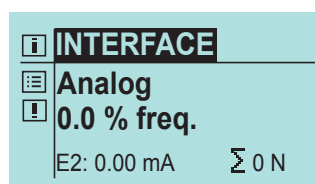
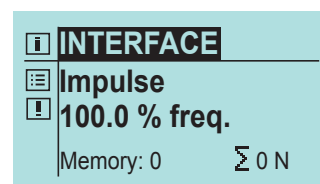
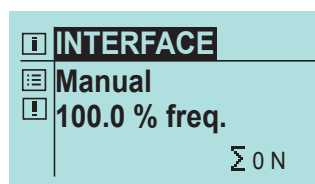

Modules

Thanks to use of the modular design, every sera dosing pump connected to the INTERFACE MODULE can be parametrised according to their own requirements. It is possible to adapt the amount of process data precisely to the needed task.

Explanation of the modules

Input data	The modules with the "CONTROL" ending are modules with process data sent to the pump. The pump can be controlled and adjusted using these.
Output data	The modules with the "STATE" ending are modules with process data received from the pump. These return the status of the pump.

The modules can be used individually depending on the application and desired operating mode. However, the „PUMP_CONTROL“ module must always be used for the control of the pump via the network as the operating mode is set here.

The pump can also be monitored for non-interface operating modes using the State modules.

All functions that can also be set using the hand-held control unit can be parametrised via the modules. Only timer operation cannot be adjusted.

The Module Status LED lights continuously after the initialisation of the module by the pump.

The Operation Mode LED indicates the network status. It lights green continuously when process data are being exchanged with a controller. It flashes green if the module is connected to a controller but no process data are being exchanged.

PROFINET acyclic data exchange

The modules can be addressed in Slot 1 and Subslot 1. Index corresponds to the module number from the module table.

Modules / Input

PUMP_CONTROL
This module is always necessary for the control of the pump irrespective of operating mode. The External Stop Bit that is valid in all operating modes can be set with this module. Other functions are the setting of the operating mode, reset of the totaliser, acknowledgement of alarms, stroke control for motor pumps. If a valid interface operating mode is selected and the pump is not in interface operation, it automatically switches to interface operation.
MANUAL_CONTROL
Adjustment of the stroke frequency / litre capacity in manual mode. The operating mode in PUMP_CONTROL must be set to Manual Interface.
PULSE_CONTROL
A pulse for executing a stroke can be sent to the pump using the pulse bit. The pulse is detected during a flank change from 0 to 1. Furthermore, the functionalities of pulse parameters are shown. The stroke frequency / litre capacity can be set using other input data.
ANALOG_CONTROL
Used for operation of the pump using analogue signal. The functionality of analogue parameters is shown via the input data. A module for parametrisation of the analogue input is required for the operation.
BATCH_CONTROL
Start of a batch, reset of the remaining batch and changeover between „normal“ or „analogue“ batch possible. Otherwise the batch quantity in strokes / litres and the stroke frequency / litre capacity can be set.
INPUT1_CONTROL, INPUT2_CONTROL, INPUT3_CONTROL
Setting of the inputs analogously to the menu.
OUTPUT1_CONTROL, OUTPUT2_CONTROL
Settings of the outputs analogously to the menu.
A_OUTPUT_CONTROL
Settings of the analogue output analogously to the menu.
SLOWMODE_CONTROL
Settings analogously to the Extras menu.
SPEED_LIMIT_CONTROL
Settings analogously to the Extras menu.
DOSING_CONTROL
Settings analogously to the Extras menu.
MBE_CONTROL
Settings analogously to the Extras menu.
LEVEL_CONTROL
Settings analogously to the Extras menu.
DEARIATION_CONTROL
Settings analogously to the Extras menu.
FLASH_CONTROL
Settings for the SD card.
TIME_CONTROL
Setting of the system time of the pump.

OPERATION

The control and parametrisation of the pump are performed using modules that are described in the following table:

No.	Module Name	Data type	Function	Comment
1	PUMP_CONTROL	Byte 1	Bit definition: 0. 0.External Stop ON/OFF 1-3 Operating mode 000 Fail Safe 001 Manual interface 010 Impulse interface 011 Analog interface 100 Batch interface 4. Reset Counter 5. Reserved 6. Acknowledge alarm message 7. Speed control	Must always be implemented to select the operating mode. If a valid interface operating mode is selected and the pump is not in interface operation, it automatically switches to interface operation. Then no other operating mode can be selected. The current stroke counter (not calibrated) and litre counter are reset using Reset Counter. The counter is maintained at 0 if the bit is set. Acknowledge alarm message using flank change to 1. Speed control only has an influence for motor pumps 0 Auto 1 Stroke frequency
2	MANUAL_CONTROL	1. Float	not calibrated: 0.0 - 100.0% calibrated 0.000 l - max. litres/hour	The decimal position of the percentage value is truncated for motor pumps. Specification in litres with up to three decimal places for calibrated pump.
3	IMPULSE_CONTROL	Byte 1 Float 2 Float 3 Word 4	Bit definition: 0. 0.Pulse 1. 1.Pulse memory ON/OFF 2-3 Pulse mode 00 Reduction 01 1/1 10 Transmission 11 Proportional Stroke frequency not calibrated: 0.0 - 100.0% calibrated: 0.000 l - max. litres/hour Pulse Upper Flow not calibrated: 0.0 - 100.0% calibrated: 0.000 l - max. litres/hour Pulse factor / pulse limit 0-999	The value means pulse limit if proportional pulse mode is selected.

No.	Module Name	Data type	Function	Comment
4	ANALOG_CONTROL	Byte 1	Bit definition:	INPUT2_CONTROL or INPUT3_CONTROL must be set as analogue input for the analogue operation.
			0-2 Analogue signal	
			00 0-20 mA	
			01 4-20 mA	
			10 Adjustment	
Byte 2	Analogue I1 0-200	Bytes 2-5 are only used standardised for analogue signal.		
Byte 3	Frequency f1 0-100%	0= 0.0 mA 200= 20.0 mA 155= 15.5 mA		
Byte 4	Analogue I2 0-200			
Byte 5	Frequency f2 0-100%			
5	BATCH_CONTROL	Byte 1	Bit definition:	The remaining batch quantity is zeroed while Bit 1 is set. Can also be used for cancellation of a batch. Batch is also reset by setting External Stop. Two analogue inputs must be parametrised accordingly for Analogue Batch. The batch can be started either by Bit 0 in Batch Control or by the digital input.
			0. Start Batch	
			1. Reset of the remaining batch	
			2. Normal batch / Analogue batch	
Float 2	Batch Volume 0.000 l - dependent on pump	Batch Flow = 0.0 can be set to pause a batch. The speed can be varied during a batch.		
Float 3	Stroke frequency not calibrated: 0.0 - 100.0% calibrated: 0.000 l - max. litres/hour			
6.1	INPUT1_CONTROL	Byte 1	Bit definition:	The function of the INPUTS / OUTPUTS can be set in bus operation by using the respective module. Otherwise, the functionality on delivery is applicable.
0-3 Input function				
0000 OFF				
0001 External stop				
0010 Venting				
0011 Impulse				
0100 Analogue 1/2 changeover				
0101 Recipe				
0110 Start Batch				
4. NC contact / NO contact				

No.	Module Name	Data type	Function	Comment
6.2	INPUT2_CONTROL	Byte 1	Bit definition: 0-3 Input function 0000 OFF 0001 External stop 0010 Venting 0011 Impulse 0100 Analog 1 0101 Recipe 0110 Start Batch 0111 Batch quantity 1000 Batch output 4. NC contact / NO contact	The function of the INPUTS / OUTPUTS can be set in bus operation by using the respective module. Otherwise, the functionality on delivery is applicable.
6.3	INPUT3_CONTROL	Byte 1	Bit definition: 0-3 Input function 0000 OFF 0001 External stop 0010 Venting 0011 Impulse 0100 Analog 2 0101 Recipe 0110 Start Batch 0111 Batch quantity 1000 Batch output 4. NC contact / NO contact	The function of the INPUTS / OUTPUTS can be set in bus operation by using the respective module. Otherwise, the functionality on delivery is applicable.
7.1	OUTPUT1_CONTROL	Byte 1	Bit definition: 0-3 Output function 0000 OFF 0001 Operational 0010 Pump active 0011 Stroke signal 0100 Pre-alarm level 0101 Dry run 0110 Diaphragm rupture 0111 No flow 1000 Group signal 1001 Group fault 1010 Internal error 1011 Batch finished 4. NC contact / NO contact	The function of the INPUTS / OUTPUTS can be set in bus operation by using the respective module. Otherwise, the functionality on delivery is applicable.

OPERATION

No.	Module Name	Data type	Function	Comment
10	SPEEDLIMIT_ CONTROL	Byte 1	Speed limit 30-100%	
11	DOSING_ CONTROL	Byte 1	Bit definition: 0-3 Sensor type 000 OFF 001 TYPE 8x9x.1 010 TYPE 801x.1 4. Warning / STOP	
		Byte 2	Fault strokes 1-100 strokes	
		Byte 3	Alarm limit 1-100%	Alarm limit only active for sensor TYPE 801x.1.
12	MBE_CONTROL	Byte 1	Bit definition: 0-1 MBE signal 00 OFF 01 NC contact 10 NO contact	
		Byte 2	Sensitivity 0-100%	
13	LEVEL_CONTROL	Byte 1	Bit definition: 0-1 Pre-alarm 00 OFF 01 NC contact 10 NO contact 2-3 Dry run 00 OFF 01 NC contact 10 NO contact	
14	DEAERATION_ CONTROL	Byte 1	Bit definition: 0. Start venting 1-2 Control 00 OFF 01 External 10 Interval 11 Automatic	Start of the venting only for external control
		Byte 2	Interval time 15-100 minutes	
		Word 3	Venting time 10-300 seconds	

No.	Module Name	Data type	Function	Comment
15	FLASH_CONTROL	Byte 1	Bit definition: 0. Signals ON/OFF 1. Operating data ON/OFF 2-3 Write period 00 1 minute 01 5 minutes 10 10 minutes 11 30 minutes	
16	TIME_CONTROL	Byte 1 Byte 2 Byte 3 Byte 4 Byte 5 Byte 6	Bit definition: 0. Set time Day 1-31 Month 1-12 Year 0-105 Hour 0-24 Minute 0-59	The time is applied when changing the bit from 0 to 1. Year starting from 2000. 0 corresponds to the year 2000. 16 corresponds to 2016. Input starting from year 2000 possible. MBE Change must be performed after setting the time to reset the timer. The old time setting is retained if an invalid date is transmitted.
17	DIACHANGE_CONTROL	Byte 1	Bit definition: 0. Start of the diaphragm change 1. Change completed	The change is started with the change of Bit 0 from 0 to 1. The change is completed with the change of Bit 1 from 0 to 1.
18	CALIBRATION_CONTROL	Byte 1 Word 2 Byte 3 Float 4	Bit definition: 0. Start Calibration 1. Cancel Calibration 2. Save Calibration Value 3. Calibration ON/OFF Calibration strokes 1-9999 strokes Calibration speed 1-100% Calibration result 0.000 - max. value in l	The calibration starts with the change of Bit 0 from 0 to 1. A valid value for the calibration strokes and calibration speed must be present. The calibration value is saved with the change of Bit 2 from 0 to 1. A value greater than 0 must exist in Float 4 and the calibration must be completed for this. Using Bit 3, the calibration can be deactivated for a calibrated pump by setting the bit to 1. The control is then performed with specification of a stroke frequency.

Data from module to the master

No.	Module Name	Data type	Function	Comment	
19	COUNTER_STATE	Float 1	Current delivered quantity Not calibrated: Strokes since switching on or reset Calibrated Litres since switching on or reset		
		Long 2 (4-byte)	Total delivered quantity In litres, since delivery of the pump		
		Long 3 (4-byte)	Total number of strokes In strokes, since delivery of the pump		
		Long 4 (4-byte)	Operating hours In hours, since delivery of the pump		
		Long 5 (4-byte)	Diaphragm hours In hours, since delivery or last diaphragm change		
20	PUMP_STATE	Byte 1	Bit definition:		
			0-3	Operation Mode	
			0000	Interface Operation Fail Safe	
			0001	Manual interface	
			0010	Pulse interface	
			0011	Analogue interface	
			0100	Batch interface	
			0101	Manual	
			0110	Pulse	
			0111	Analogue	
			1000	Batch	
			1001	Reserved	
			1010	Timer	
			Byte 2	Pump State 2	Bit 1 changes from 0 to 1 for 160 ms after each performed stroke.
		0.	Pump OFF/ON		
1.	Stroke signal				
2.	Group signal present				
3.	Group fault present				
4.	Acknowledgement of error message performed				
5.	Diaphragm change active				
7.	Pump calibrated No / Yes				

No.	Module Name	Data type	Function	Comment
21	FLOW_STATE	Float 1	Current delivery rate not calibrated: 0.0 - 100.0% calibrated: 0.000 l - max. litres/hour	
22	PULSE_STATE	Byte 1	Bit definition: 0. Pulse 1. Pulse memory ON/OFF 2-3 Pulse mode 00 Divisor 01 1/1 10 Multiplier 11 Proportional	
		Word 1	Pulse Memory 0-999	Registered pulses
23	ANALOGUE_STATE	Byte 1	Bit definition: 0-2 Analogue signal 00 0-20 mA 01 4-20 mA 10 Standardised	
		Byte 2	Analogue I1 0-200	
		Byte 3	Analogue Frequency f1 0-100%	
		Byte 4	Analogue I2 0-200	
		Byte 5	Analogue Frequency f2 0-100%	0= 0 mA 150= 15.0 mA 200= 20.0 mA
		Byte 6	Analogue Current 0-250	The current at the active input is displayed.
24	BATCH_STATE	Byte 1	Bit definition: 0. Batch is being conveyed	
		Float 2	Batch volume Specification according to BATCH_CONTROL or using analogue input	
		Float 3	Batch speed Specification according to BATCH_CONTROL	
		Float 4	Remaining batch quantity 0.001 l - max. batch volume	

OPERATION

No.	Module Name	Data type	Function	Comment
25.1	INPUT1_STATE	Byte 1	Bit definition: 0-3 Input function 0000 OFF 0001 External stop 0010 Venting 0011 Pulse 0100 Analogue changeover 0101 Recipe 0110 Start Batch 4. NC contact / NO contact 5. set / not set	
25.2	INPUT2_STATE	Byte 1	Bit definition: 0-3 Input function 0000 OFF 0001 External stop 0010 Venting 0011 Pulse 0100 Analogue 1 0101 Recipe 0110 Start Batch 0111 Batch quantity 1000 Batch output 4. NC contact / NO contact 5. set / not set	5. Bit not applicable for analogue function.
25.3	INPUT3_STATE	Byte 1	Bit definition: 0-3 Input function 0000 OFF 0001 External stop 0010 Venting 0011 Pulse 0100 Analogue 1 0101 Recipe 0110 Start Batch 0111 Batch quantity 1000 Batch output 4. NC contact / NO contact 5. set / not set	

No.	Module Name	Data type	Function	Comment
26.1	OUTPUT1_STATE	Byte 1	Bit definition: 0-3 Output function 0000 OFF 0001 operational 0010 Pump active 0011 Stroke signal 0100 Pre-alarm level 0101 Dry run 0110 Diaphragm rupture 0111 No flow 1000 Group signal 1001 Group fault 1010 Internal error 1011 Batch finished 4. NC contact / NO contact 5. set / not set	
26.2	OUTPUT2_STATE	Byte 1	Bit definition: 0-3 Output function 0000 OFF 0001 operational 0010 Pump active 0011 Stroke signal 0100 Pre-alarm level 0101 Dry run 0110 Diaphragm rupture 0111 No flow 1000 Group signal 1001 Group fault 1010 Internal error 1011 Batch finished 4. NC contact / NO contact 5. set / not set	
27	A_OUTPUT_STATE	Byte 1	Analogue Out Current 0-200	0= 0 mA 150= 15.0 mA 200= 20.0 mA

OPERATION

No.	Module Name	Data type	Function	Comment
28	CALIBRATION_STATE	Byte 1	Bit definition: 0. Start Calibration 1. Cancel Calibrati- on 2. Save Calibration Value 3. Calibration ON/ OFF 4. Calibration active 5. Calibration finis- hed	
		Word 1	Calibration Remain Strokes 0-999	
29	PUMP_INFO_STATE	Float 1	MAX_FLOW Maximum delivery rate in l/h	
		Word 1	MAX_STROKE Maximum stroke frequency in strokes/minute	
		Word 1	SERA-CODE 0-65535	
		Long 1	SERIAL_NUMBER 0-9999999	
		Byte 1	SW vM01.xxx	
		Byte 1	HW vHC01.xxx	

The last three digits of the hardware and software versions are transmitted.

No.	Module Name	Data type	Function	Comment	
30	ALARM_STATE	Long 1 (4-byte)	Byte 1		
			Bit 0	Drive fault	
			Bit 1	Out of calibration range	Bit 1 (only pumps with HLE)
			Bit 2	Setpoint cannot be achieved	
			Bit 3	Fault stroke sensor	
			Bit 4	No stroke detection	
			Bit 5	Reserved	
			Bit 6	Drive too slow	
			Bit 7	Reserved	
			Bit 8	Diaphragm rupture	
			Bit 9	Pre-alarm level	
			Bit 10	Dry run level	
			Bit 11	Mains voltage too high	
			Bit 12	Mains voltage too low	
			Bit 13	no flow, only for active flow rate monitoring	
			Bit 14	Flow rate too low	
			Bit 15	Pulse memory overflow	
			Bit 16	Overtemperature, only stepper motor pump	
			Bit 17	Service time exceeded	
			Bit 18	SD card fault	
			Bit 19	Analogue signal > 20 mA	
			Bit 20	Analogue signal < 4 mA	
			Bit 21	Analogue signal > 25mA	
			Bit 22	Reserved	
			Bit 23	Reserved	
			Bit 24	Reserved	
			Bit 25	Reserved	
			Bit 26	Reserved	
			Bit 27	Reserved	
			Bit 28	Reserved	
			Bit 29	Reserved	
			Bit 30	Reserved	
			Bit 31	Reserved	

Diagnostics signals

The **sera** INTERFACE MODULE has two diagnostics messages that are output in the network-specific protocol (PROFIBUS / PROFINET). A present message is indicated by flashing once for a short time of the Module Status LED. The messages can be read in plain text using the diagnostics function of the Engineering tool.

The following messages can be generated:

- PUMP_WARNING
There is a signal in the pump. The pump is still operational.
- PUMP_ERROR
There is a fault in the pump. The pump is not operational.
- ALARME_STATE
The module can be used to evaluate the error.

Error message

Error message	Possible cause	Corrective action
Fault bus module	Module has been removed from the pump during operation.	Disconnect voltage. Connect module to pump. Switch on voltage again.
Fault bus module	Internal error of the communication module.	Please contact the manufacturer.

Maintenance and cleaning

The INTERFACE MODULE is maintenance-free. Clean with a moist cloth. Rub dry afterwards.

ATTENTION

Do not use any solvents! These can attack the surfaces.

Decommissioning

- Disconnect device from the power supply.
- Detach electrical connections.
- Take device out of operation.

ATTENTION

Only let the decommissioning be performed by authorised and qualified personnel.

Disposal

Dispose of correctly and comply with the currently applicable local regulations after shutdown and dismantling.

ATTENTION

Dispose of electronics separately!

FOLLOW US



sera GmbH

sera-Str. 1
34376 Immenhausen
Germany
Tel. +49 5673 999 00
Fax +49 5673 999 01
info@sera-web.com
www.sera-web.com